

Hybrid Differential Evolution Particle Swarm Optimization Algorithm

K. Naresh
EEE Department
KL University
Guntur, A.P, India
knaresh@kluniversity.in

Vaddi.Ramesh
EEE Department
KL University
Guntur, A.P, India
Rameshvaddi6013@kluniversity.in

CH. Punya Sekhar
EEE Department
AN University
Guntur, A.P, India
Punya286@gmail.com

Giridhar Balakrishna R
EEE Department
V R Siddhartha Engineering College
Vijayawada, A.P, India
Balu.eee214@gmail.com

P. Yoganada Reddy
EEE Department
V R Siddhartha Engineering College
Vijayawada, A.P, India
Yogi244@gmail.com

Abstract— In an alternating current system, if the system is resistive i.e. voltage and current are in phase only real power is transmitted and if there is a time shift between voltage and current both active and reactive power are transmitted. When the average with respect to time is calculated, the average active power exists causing a net flow of energy from one point to another, whereas average reactive power is zero, irrespective of the network or state of the system. In the case of reactive power, the amount of energy flowing in one direction is equal to the amount of energy flowing in the opposite direction (or different parts -capacitors, inductors, etc- of a network, exchange the reactive power). That means reactive power is neither produced nor consumed. The reactive power optimization problem has a significant influence on secure and economic operation of power systems. Reactive power optimization is a mixed integer nonlinear programming problem where meta-heuristics techniques have proven suitable for providing optimal solutions. In this project, swarm and evolutionary algorithm have been applied for reactive power optimization. A hybrid differential evolution particle swarm optimization algorithm is developed to solve the reactive power optimization problem.

Differential Evolution (DE) and Particle Swarm Optimization (PSO) are population-based optimization algorithms. Due to their excellent convergence characteristics and few control parameters, DE and PSO have been applied to obtain optimal solutions to some real valued problems efficiently. However, because of its no use of global information about the search space, DE may be trapped in local optima. Basic PSO has drawbacks slow search speed and low convergence accuracy. Inspired by advantages and disadvantages of DE and PSO respectively, a hybrid of DE and PSO gives a new method of optimization called Hybrid Differential Evolution Particle Swarm Optimization Algorithm (DEPSO). DEPSO takes the most CPU execution time among the three algorithms under the same iterations but the active power loss is drastically reduced and the solution by PSOPDE is converged to high quality solutions at the early iterations. The proposed DEPSO is applied for reactive power optimization on the IEEE 10-bus systems in MATLAB 7.0 language. This project presents and compares three algorithms based on swarm intelligence and evolutionary techniques for solving the reactive power optimization problem Case studies on

the IEEE 10-bus,34-bus systems illustrate the effectiveness of these algorithms in terms of the quality of the solutions found and their convergence characteristics. The results proved that the proposed DEPSO algorithm provides higher-quality solution with smaller iterations than the other two methods. DEPSO indeed outperforms DE or basic PSO method on this problem when comparing power loss reduction and number of iterations required for achieving convergence.

Keywords—Differential Evolution, Particle Swarm Optimization, Hybrid Differential Evolution Particle Swarm Optimization Algorithm.

I. INTRODUCTION

A power system is an interconnected system composed of generation stations, which convert fuel energy into electrical energy, sub-station that distribute electrical power to loads (consumers) and transmission lines that tie the generating station and distribution substation together. According to the voltage levels, an electrical power systems can be viewed as consisting of a generating station, a transmission system and a distribution system. A part of power system which distributes the electrical power for local use is known as “Distribution system”. It lies between the substation fed by the transmission system and the consumer meters. The typical diagram of distribution system is shown in fig.1.1.

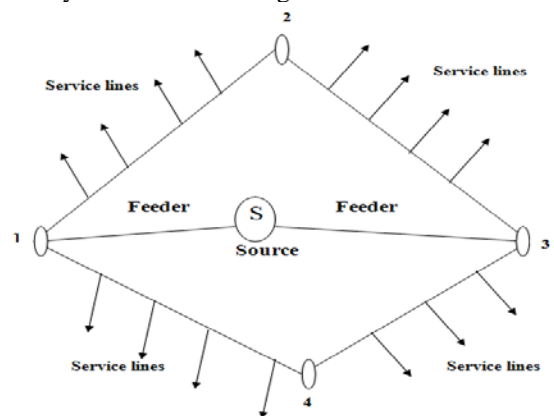

Fig.1.1 A typical distribution system

The transmission system is distinctly different from the distribution system. Where the transmission system draws power from the single source and transmits it to individual loads, the transmission system not only handles the largest blocks of power but also the system.

A. Need For Capacitor Placement

Distribution systems are the networks that transport the electric energy from bulk substation to many services or loads, thus causes more power and energy losses. Hence there is a need to reduce the system losses. By minimizing the power losses, the system may acquire longer life span and has greater reliability. Loss minimization in distribution systems has assumed greater significance recently since the trend towards distribution automation will require the most efficient operating scenario for economic viability. Studies have indicated that as much as 13% of total power generated is consumed I^2R as losses at the distribution level. Reactive currents account for a portion of these losses. However, the losses produced by reactive currents can be reduced by the installation of shunt capacitors. Effective capacitor installation can also release additional KVA capacity from distribution apparatus and improve the system voltage profile. Reactive power compensation plays an important role in the planning of an electrical system.

As Distribution Systems are growing large and being stretched too far, leading to higher system losses and poor voltage regulation, the need for an efficient and effective distribution system has therefore become more urgent and important. In this regard, Capacitor banks are added on Radial Distribution system for Power Factor Correction, Loss Reduction and Voltage profile improvement. The amount of compensation provided is very much linked to the placement of capacitors in the distribution system, which is essentially determination of the location, size, number and type of capacitors to be placed in the system.

B. Survey

With these various Objectives in mind, Optimal Capacitor Placement aims to determine Capacitor location and its size. Optimal Capacitor Placement has been investigated over decades. Early approaches were based on heuristic techniques [1]. The optimal capacitor placement is a complicated combinatorial optimization problem, many different optimization techniques and algorithms have been proposed in the past. Sundharajan and Pahwa proposed the genetic algorithm approach to determine the optimal placement of capacitors based on the mechanism of natural selection [2]. D.Das proposed the genetic algorithm approach for reactive power compensation in distribution systems to reduce the energy loss under varying load conditions [3]. Chiou *et al*, proposed the Variable Scaling Hybrid Differential Evolution with integer programming for solving large capacitor placement problems in distribution systems [4]. Chung *et al*, used a robust searching hybrid differential evolution method for optimal reactive power planning in large scale distribution

systems [5]. Here, the authors introduced two new schemes, multi-direction search scheme and search space reduction scheme, into Hybrid Differential Evolution scheme. Prakash and Sydulu proposed the Particle swarm optimization method to size the capacitors in distribution system capacitor placement problem [6].

In the present work, a new approach consists of a combination of particle swarm optimization and differential evolution is proposed for sizing of capacitors in the distribution system. DE has the ability to maintain the diversity of population, but it has no mechanism of memory the previous process and uses the global information about the search space, so it easily results in waste of computing power and gets trapped in local optima. PSO has a strong ability to find the global optimal solution accurately and rapidly. But, in some cases, it is found that PSO get stuck in local optima at an early stage and resulted in non-improvement during remaining iterations because of lost of diversity of swarm. Inspired by the advantages and disadvantages of DE and PSO, a new scheme called DEPSO is proposed in this paper. In DEPSO, in order to maintain diversity and explore the search space more efficiently, the PSO algorithm is incorporated into the DE algorithm and the particle position is updated partly in the DE way, partly in PSO normal updating way. The proposed method is tested on 10 bus radial distribution systems and results obtained are promising.

II. LOAD FLOW TECHNIQUE

A. Introduction

In this thesis little attention has been given to load-flow analysis of distribution systems, unlike load-flow analysis of transmission systems. However, some work has been carried out on load-flow analysis of distribution networks, but the choice of a solution method for a practical system is often difficult. Generally, distribution networks are radial and the R/X ratio is very high. For the reason, conventional Newton-Raphson (NR) and Gauss Seidel (GS) load-flow methods do not converge. Many researchers have suggested modified versions of the conventional load-flow methods for solving power networks with high R/X ratio.

An efficient method for load-flow solution of radial distribution network has been proposed in this project. The proposed method reduces the data preparation. The Proposed method simply needs starting nodes of feeder, lateral(s) and sub lateral(s) and no data of branch numbers for sequential numbering scheme. If the node and branch numbers are not sequential, only node numbers and branch numbers of each feeder lateral(s) and sub lateral(s) are required. Therefore, the proposed method consumes less computer memory. The proposed method uses the simple voltage equation. The proposed method takes the zero initial loss for computation of voltage of each node and considers flat voltage start to incorporate voltage convergence.

B. Assumptions

It is assumed that three-phase radial distribution networks are balanced and represented by their single-line diagrams and charging capacitances are neglected at the distribution voltage levels.

C. Solution Methodology

A single line diagram of a radial distribution network is shown in Fig.2.1 with sequential numbering. In Fig. 2.1, the node and branch numbering scheme have been shown sequential. From Fig.2.1, set of nodes of feeder, lateral and sub lateral are $FN=\{1,2,3,4,5,6\}$, $LN=\{3,7,8\}$ and $SLN=\{7,9,10\}$ respectively. In Fig.2.1 the set of branch number of feeder are $FB = \{1,2,3,4,5\}$, $LB=\{6,7\}$ and $SLB = \{8,9\}$ respectively .Fig. 2.2 shows when the node and branch numbering scheme are not sequential. From Fig. 2.2, set of nodes of feeder, lateral and sub lateral are $FN=\{1,6,4,8,10,2\}$, $LN=\{4,9,3\}$ and $SLN=\{9,7,5\}$ respectively. In Fig. 2.1 the set of branch number of feeder are $FB = \{1,7,3,9,5\}$, $LB=\{6,2\}$ and $SLB = \{8,4\}$ respectively.

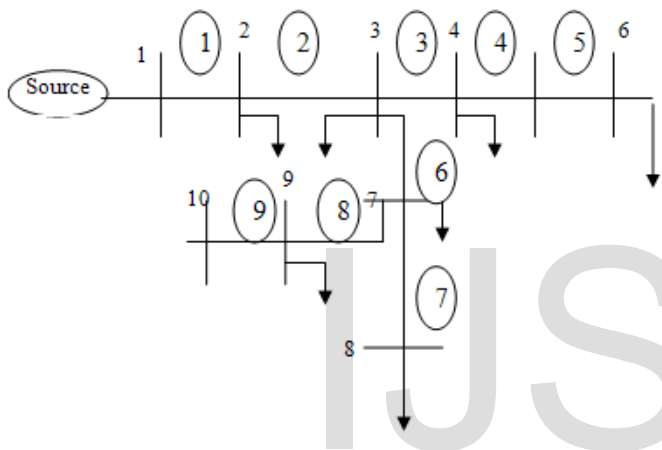

Fig.2.1. Single-line diagram of a Radial Distribution System with sequential circuit

Fig. 2.2 shows when the node and branch numbering scheme are not sequential. From Fig. 2.2, set of nodes of feeder, lateral and sub lateral are $FN=\{1,6,4,8,10,2\}$, $LN=\{4,9,3\}$ and $SLN=\{9,7,5\}$ respectively. In Fig. 2.1 the set of branch number of feeder are $FB = \{1,7,3,9,5\}$, $LB=\{6,2\}$ and $SLB = \{8,4\}$ respectively.

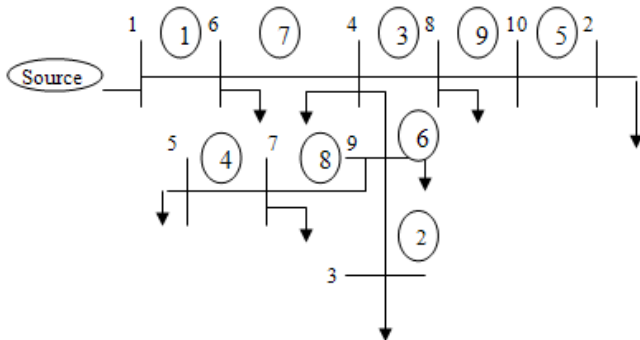

Fig. 2.2 shows when the node and branch numbering scheme are not sequential.

From Fig.2.1 and Fig. 2.2, the sub lateral has two branches, the lateral has two branches and the feeder has five branches. Let the feeder is denoted by 1, lateral by 2 and sub lateral by 3 in Fig.2.1 and Fig. 2.2. Here the two dimensional array FN denotes the node of feeder, each lateral and each sub lateral where the first number of the array indicates feeder, lateral and sub lateral. At first feeder is kept, then lateral and sub lateral. The second number denotes the order of the node of the set.

From Fig. 2.1, the nodes of feeder, lateral and sub lateral are shown below.

$FN(1,1) = 1, FN(1,2) = 2, FN(1,3) = 3, FN(1,4) = 4, FN(1,5) = 5$ and $FN(1,6) = 6$

$FN(2,1) = 3, FN(2,2) = 7$ and $F(2,3) = 8$ and $FN(3,1) = 7, FN(3,2) = 9$ and $F(3,3) = 10$.

From Fig. 2.1, the branches of feeder, lateral and sub lateral are shown below.

$FB(1,1) = 1, FB(1,2) = 2, FB(1,3) = 3, FB(1,4) = 4$ and $FB(1,5) = 5$

$FB(2,1) = 6$ and $FB(2,2) = 7$ and $FB(3,1) = 8$ and $FB(3,2) = 9$.

From Fig. 2.2, the nodes of feeder, lateral and sub lateral are shown below.

$FN(1,1) = 1, FN(1,2) = 6, FN(1,3) = 4, FN(1,4) = 8, FN(1,5) = 10$ and $FN(1,6) = 2$ $FN(2,1) = 4, FN(2,2) = 9$ and $F(2,3) = 3$ and $FN(3,1) = 9, FN(3,2) = 7$ and $F(3,3) = 5$.

From Fig. 2.2, the branches of feeder, lateral and sub lateral shown below.

$FB(1,1) = 1, FB(1,2) = 7, FB(1,3) = 3, FB(1,4) = 9$ and $FB(1,5) = 5$ $FB(2,1) = 6$ and $FB(2,2) = 2$ and $FB(3,1) = 8$ and $FB(3,2) = 4$.

D. Load-flow Calculations

Let $jj = FB(i,j)$, $m2 = FN(i,j+1)$ and $m1 = FN(i,j)$. We have

$$V(m2) = V(m1) - I(jj)Z(jj)$$

Let $V(m2) = V(m2) \angle \delta 2$

$$V(m1) = V(m1) \angle \delta 1$$

$$Z(jj) = Z(jj) \angle \theta = R(jj) + jX(jj) \text{ and}$$

$$I(jj) = I(jj) \angle -\theta$$

Voltage of node m2 is expressed by

$$V(m2) = V(m1) - \frac{[P_s^2(jj) + Q_s^2(jj)]^{1/2} Z(jj)}{V(m1)} \quad (2.1)$$

Where $P_s(jj)$ and $Q_s(jj)$ are the real and reactive powers coming out from the node m1. The detailed derivation has been shown in Appendix A. Voltage of node m2 can also be calculated using the following expression also:

$$|V(m2)| = \frac{V(m1) \pm \sqrt{V(m1)^2 - 4\sqrt{\{P_r^2(jj) + Q_r^2(jj)\}}Z(jj)}}{2} \quad (2.2)$$

where $P_r(jj) = P_s(jj) - LP(jj)$ and $Q_r(jj) = Q_s(jj) - LQ(jj)$ are the real and reactive power fed through the node m2. Equation (2) is used to calculate $|V(m2)|$ due to its simplicity. The current through the branch- jj is expressed by

$$|I(jj)| = \frac{V(m1) - V(m2)}{Z(jj)} \quad (2.3)$$

The real and reactive power loss of branch- jj is expressed by

$$|LP(jj)| = |I(jj)|^2 R(jj) \quad (2.4)$$

$$|LQ(jj)| = |I(jj)|^2 X(jj) \quad (2.5)$$

$P_s(jj)$ = Sum of real power load of all nodes after the branch-jj plus the real power loss of all the branches after the branch-jj including the branch-jj also. $Q_s(jj)$ = Sum of reactive power load of all nodes after the branch-jj plus the reactive power loss of all the branches after the branch-jj including the branch-jj also.

To discuss the calculation of $P_s(jj)$ and $Q_s(jj)$, $P_s(jj)$ and $Q_s(jj)$ for sub lateral(s), lateral(s) and feeder are calculated at first with an assumption that they are separated.

For the sub lateral

$$\left. \begin{aligned} [FB(3,2)] &= PL[FN(3,3)] + LP[FB(3,2)] \\ P_s[FB(3,1)] &= PL[FN(3,2)] + LP[FB(3,1)] + P_s[FB(3,2)] \end{aligned} \right\} (2.6)$$

$$\left. \begin{aligned} P_s[FB(2,2)] &= PL[FN(2,3)] + LP[FB(2,2)] \\ P_s[FB(2,1)] &= PL[FN(2,2)] + LP[FB(2,1)] + P_s[FB(2,2)] \end{aligned} \right\} (2.7)$$

$$\left. \begin{aligned} P_s[FB(1,5)] &= PL[FN(1,6)] + LP[FB(1,5)] \\ P_s[FB(1,4)] &= PL[FN(1,5)] + LP[FB(1,4)] + P_s[FB(1,5)] \\ P_s[FB(1,3)] &= PL[FN(1,4)] + LP[FB(1,3)] + P_s[FB(1,4)] \\ P_s[FB(1,2)] &= PL[FN(1,3)] + LP[FB(1,2)] + P_s[FB(1,3)] \\ P_s[FB(1,1)] &= PL[FN(1,2)] + LP[FB(1,1)] + P_s[FB(1,2)] \end{aligned} \right\} (2.8)$$

From (2.6), (2.7) and (2.8), we can conclude the following:

For the end branch

$$P_s[FB(i, j)] = PL[FN(i, j+1)] + LP[FB(i, j)] \quad (2.9)$$

and for other branches,

$$P_s[FB(i, j)] = PL[FN(i, j+1)] + LP[FB(i, j)] + P_s[FB(i, j+1)] \quad (2.10)$$

Equations(10) and (11) shows generalized expressions for the computation of P_s 's through the feeder, lateral and sublateral when they are separated. Similarly, the following are the generalized expressions for Q_s 's:

For the end branch

$$Q_s[FB(i, j)] = QL[FN(i, j+1)] + LQ[FB(i, j)] \quad (2.11)$$

and for other branches,

$$Q_s[FB(i, j)] = QL[FN(i, j+1)] + LQ[FB(i, j)] + Q_s[FB(i, j+1)] \quad (2.12)$$

Now from Fig. 1 and Fig. 2, we have the following:

Sub lateral is connected to lateral at the node F(2,2).

Therefore, power flow through

The branch FB (2, 1) becomes

$$P_s[FB(2,1)] = PL[FN(2,2)] + LP[FB(2,1)] + P_s[FB(2,2)] + P_s[FB(3,1)] \quad (2.13)$$

and

$$Q_s[FB(2,1)] = QL[FN(2,2)] + LQ[FB(2,1)] + Q_s[FB(2,2)] + Q_s[FB(3,1)] \quad (2.14)$$

The lateral is connected to feeder at the node F(1,3).

Therefore, power flow through the branch FB(1,2) becomes

$$P_s[FB(1,2)] = PL[FN(1,3)] + LP[FB(1,2)] + P_s[FB(1,3)] + P_s[FB(1,1)] \quad (2.15)$$

and

$$Q_s[FB(1,2)] = QL[FN(1,3)] + LQ[FB(1,2)] + Q_s[FB(1,3)] + Q_s[FB(1,1)] \quad (2.16)$$

From the above discussion, it can be concluded that the common nodes of among the sub lateral(s) and lateral(s) as well as that of feeder and lateral(s) must be marked at first.

If FN(i,j) be the node of lateral which is the source node of the sub lateral also or be the node of feeder which is the source node of the lateral also, the branch number FB(i,j-1) is required to be stored. The proposed logic checks the common nodes of lateral(s) and sub- lateral(s) [first node of the sub lateral(s)] and also stores the branch number. If the node FN(i,j) of the lateral and first node FN(x,1) of the sub lateral are identical, the branch FB(i,j-1) of the lateral to be stored in the memory say the variable mm[TN-1] where TN is the total number denoting the sum of numbers of feeder, lateral(s) and sub lateral(s) and the sub lateral number is also stored in the array mn[TN-1]. Here TN-1 shows the total memory size of the array. Similarly, the common nodes of lateral(s) and feeder are found out and the branch number of the feeder corresponding to the common node of feeder and lateral are stored in mm[TN-1] and simultaneously lateral number is stored in mn[TN-1]. The branches of lateral(s) and feeder(s) are checked with the branches stored in the array mm[TN-1]. If any branch number of lateral and feeder matches with any element of mm[TN-1], say the branch number of FB(i,j) matched with mm[2], the P_s and Q_s for the branch FB(i,j) will be

$$P_s[FB(i, j)] = PL[FN(i, j+1)] + LP[FB(i, j)] + P_s[FB(i, j+1)] + P_s[FB(mn[2],1)] \quad (2.17)$$

And

$$Q_s[FB(i, j)] = QL[FN(i, j+1)] + LQ[FB(i, j)] + Q_s[FB(i, j+1)] + Q_s[FB(mn[2],1)] \quad (2.18)$$

Where mn[2] is the number of lateral or sub lateral depending of the value of i. From above discussion, it is clear that the proposed method does not depend upon the node and branch numbering.

To make the computation of P_s and Q_s faster, the logic used in the proposed method is described below:

Step 1: Get the number of Feeder(A), lateral(s) (B) and sub lateral(s) (C).

Step 2: $TN = A + B + C$

Step 3: Read total number of nodes of feeder, each lateral and sub lateral respectively i.e., N(i) for $i = 1, 2, \dots, TN$.

Step 4: Get the status of numbering scheme.

Step 5: If it is sequential, ask for the starting node of feeder, each lateral and sub lateral respectively. Go to Step 7.

Step 6: If it is not sequential, read the set of nodes as well as branches of feeder, each lateral and sub lateral respectively.

Step 7 : Find the common nodes of sub lateral(s) and lateral(s) i.e., FN(i,1) for i = TN to TN-C+1 from FN(i,j) for j = 1,2,...,N(i) and i = TN-C to TN-C-B. Store them in mm(i) for i = 1,2,...,C and store the branch of lateral FB(i,j-1) corresponding to the node FN(i,j) in mn(i) for i=1,2,...,C.

Step 8: Find the common nodes of lateral(s) and Feeder i.e., FN(i,1) for i = TN-C to TN-C-B+1 from FN(1,j) for j = 1,2,...,N(1). Store them in mm(i) for i = C+1,...,C+B and the branch of feeder FB(i,j-1) corresponding to the node FN(i,j) in mn(i) for i=C+1,...,C+B.

Step 9 : Calculate Ps[FB(i,j)] and Qs[FB(i,j)] for j = N(i)-1 ,...,2,1 and for i = TN to TN-C+1 using (10) or (11) and (12) or (13) respectively.

Step10: Calculate Ps[FB(i,j)] and Qs[FB(i,j)] for j = N(i)-1 ,...,2,1 and for i = TN-C to TN-C-B+1 using (18) and (19) respectively with a check of FB(i,j) for j = N(i)-1 ,...,2,1 and for i = TN-C to TN-C-B+1 with mn(k) for k=1,2,...,C.

Step11: Calculate Ps[FB(1,j)] and Qs[FB(1,j)] for j = N(i)-1 ,...,2,1 using (18) and (19) respectively with a check of FB(1,j) for j = N(i)-1 ,...,2,1 with mn(k) for k=C+1,...,C+B.

III. CAPACITOR PLACEMENT PROBLEM

A. Problem Formulation

The objective of capacitor placement in the distribution system is to minimize loss of the system, subjected to certain operating constraints and load pattern. For simplicity, the operation and maintenance cost of the capacitor placed in the distribution system is not taken into consideration. The three-phase system is considered as balanced and loads are assumed as time invariant.

Mathematically, the objective function of the problem is described as:

$$\text{Minimize } f = \min(P_{T, Loss}) \quad (3.1)$$

$$\text{Subjected to } V_{\min} \leq |V_i| \leq V_{\max} \quad (3.2)$$

$$|I_i| \leq |I_{i, \max}| \quad (3.3)$$

Where $P_{T, Loss}$ is the total real power loss of the system;

$|V_i|$ voltage magnitude of bus i ;

V_{\min}, V_{\max} are bus minimum and maximum voltage limits.

$I_i, I_{i, \max}$ current magnitude and maximum current limit of branch i ; The power flows are computed by the following set of simplified recursive equations derived from the single line diagram depicted in Fig. 3.1 [8].

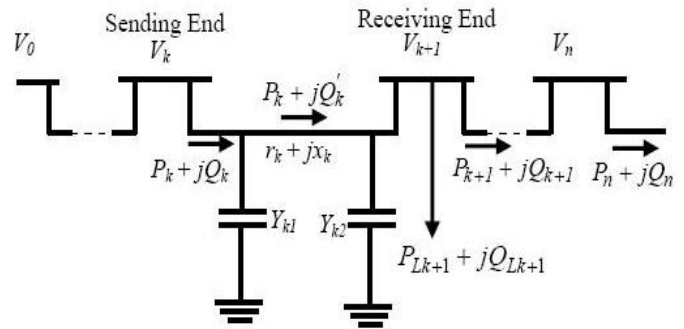

Fig. 3.1 Single Line Diagram of a Main Feeder

$$P_{k+1} = P_k - P_{Loss,k} - P_{Lk+1} \\ = P_k - \frac{r_k}{|V_k|^2} \left\{ P_k^2 + (Q_k + Y_k |V_k|^2)^2 \right\} - P_{Lk+1} \quad (3.4)$$

$$Q_{k+1} = Q_k - Q_{Loss,k} - Q_{Lk+1} \\ = Q_k - \frac{x_k}{|V_k|^2} \left\{ P_k^2 + (Q_k + Y_{k1} |V_k|^2)^2 \right\} - Y_{k1} |V_k|^2 \\ - Y_{k2} |V_{k+1}|^2 - Q_{Lk+1} \quad (3.5)$$

$$|V_{k+1}|^2 = |V_k|^2 + \frac{r_k^2 + x_k^2}{|V_k|^2} (P_k^2 + Q_k^2) - 2(r_k P_k + x_k Q_k) \\ = |V_k|^2 + \frac{r_k^2 + x_k^2}{|V_k|^2} (P_k^2 + (Q_k + Y_k |V_k|^2)^2) \\ - 2(r_k P_k + x_k (Q_k + Y_k |V_k|^2)) \quad (3.6)$$

where P_k and Q_k are the real and reactive powers flowing out of bus k , and P_{Lk+1} and Q_{Lk+1} are the real and reactive load powers at bus $k+1$. The shunt admittance is denoted by Y_{kl} at any bus k to ground. The resistance and reactance of the line section between buses k and $k+1$ are denoted by r_k and x_k , respectively. The power loss of the line section connecting buses k and $k+1$ may be computed as

$$P_{Loss}(k, k+1) = r_k \cdot \frac{(P_k^2 + Q_k^2)}{|V_k|^2} \quad (3.7)$$

The total power loss of the feeder, $P_{T, Loss}$, may then be determined by summing up the losses of all line sections of the feeder, which is given as

$$P_{T, Loss} = \sum_{k=0}^{n-1} P_{Loss}(k, k+1) \quad (3.8)$$

Considering the practical capacitors, there exists a finite number of standard sizes which are integer multiples of the smallest size Q_o^c . Besides, the cost per kVAr varies from one size to another. In general, capacitors of larger size have lower unit prices. The available capacitor size is usually limited to

$$Q_{\max}^c = LQ_o^c \quad (3.9)$$

where L is an integer.

Therefore, for each installation location, there are L capacitor sizes $\{ Q_o^c, 2 Q_o^c, 3 Q_o^c, \dots, L Q_o^c \}$ available. where n is number of candidate locations for capacitor placement, for $i = 1, 2, \dots, n$ are the indices of the buses selected for compensation. The bus reactive compensation power is limited to

$$Q_i^c \leq \sum_{i=1}^n QLi \quad (3.10)$$

where Q_i^c and QLi are the reactive power compensated at bus i and the reactive load power at bus i , respectively

IJSER

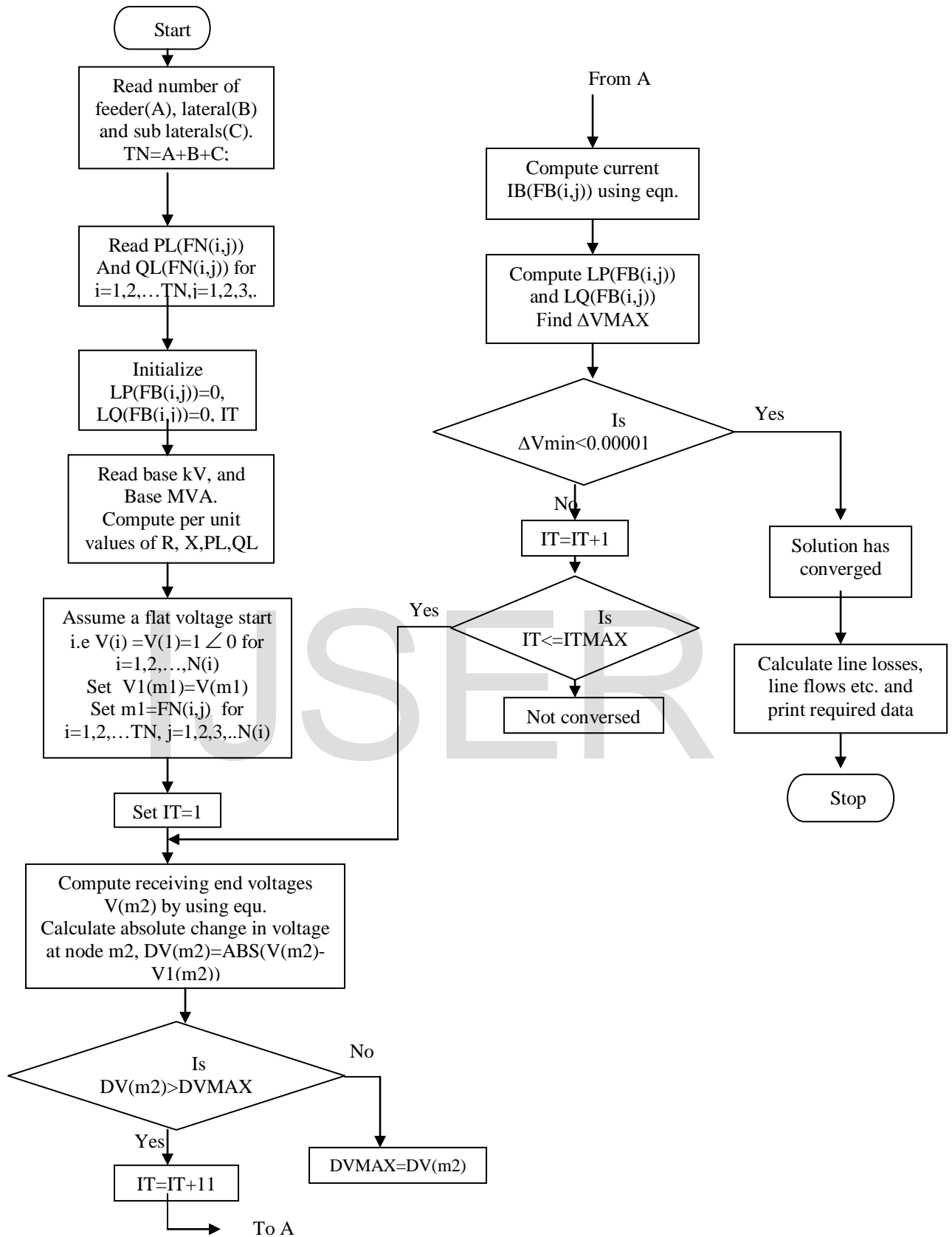

Fig.2.3: Flowchart for load flow calculation of radial distribution network

IV. PARTICLE SWARM OPTIMIZATION WITH DIFFERENTIAL EVOLUTION (DEPSO) ALGORITHM

In this section a brief overview of the Differential Evolution (DE) and the Particle Swarm Optimization (PSO) is provided. Next, a new scheme combining the DE and PSO called DEPSO is proposed.

A. Particle Swarm Optimization With Differential Evolution (DEPSO)

Though DE has some advantages, such as its ability to maintain the diversity of population, and to explore the local search, but it has no mechanism of memory the previous process and use the global information about the search space, so it easily results in waste of computing power and gets trapped in local optima. This disadvantage comes from the two aspects of DE: greedy updating method and intrinsic differential property. The greedy updating strategy results in premature of DE, while the differential operation in maintaining the premature status of DE. PSO has a strong ability to find the global optimal solution accurately and rapidly. But, in some cases, it is found that PSO get stuck in local optima at an early stage and resulted in non improvement during remaining iterations because of lost of diversity of swarm. Inspired by the advantages and disadvantages DE and PSO, a new scheme called DEPSO is proposed in this section. In the DEPSO, particle's position is updated partly in the DE way, partly in PSO normal updating. Therefore, this scheme can explore the search space more efficiently.

The procedure of DEPSO is described as follows:

1. Initialize Maximum number of generations (*MNG*), gene, Population size, Particle *i* with random position x_{ij} and velocity v_{ij} , $pbest_{ij}$ to the position of the current particle and other constants;
2. Set gene to zero;
3. Calculate the objective function $f(x_{ij})$ and evaluate it;
4. Generate the population in the following way:
 From $i=1$ to population size and $j=1$ to Dimension,
 if (random () < CR) then, Generate $x_{ij}^{candidate}$ in DE way,
 Otherwise, Generate $x_{ij}^{candidate}$ using PSO updating rule;
5. Calculate objective function $f(x_{ij}^{candidate})$ and evaluate it;
6. If $f(x_{ij}^{candidate}) < f(x_{ij})$ then assign candidate $x_{ij}^{candidate}$ to x_{ij} and $f(x_{ij}^{candidate})$ to $pbest_{ij}$, otherwise retain the current positions;
7. Set gene= gene+1;
8. If function value is not converged or gene is less than *MNG* go to step 4, otherwise go to step 9;
9. Output the result.

V. SIMULATION RESULTS

The proposed method was tested on 10-bus [7] results have been obtained to evaluate its effectiveness. The proposed method has been programmed using MATLAB and run on a Pentium IV, 3-GHz personal computer with 0.99 GB RAM. In order to illustrate the application and demonstrate the effectiveness of the proposed method, two application examples are employed. The simulation results obtained by the proposed method are given below.

A. 10 Bus Radial Distribution System

The first test case for the proposed method is a 10-bus, 23 kV, radial distribution system [7] as shown in fig.5.1. It consists of single feeder with zero laterals. The line and load data of the network is obtained from appendix. [A], and the total reactive load on the system is 4186 kVar. For this test case, parameters were selected as: Maximum number of iterations=300; Mutation factor $F=0.8$; Cross over factor $CR=0.9$. $kVar_{min}=200$; $kVar_{max}=1200$; $c_1=c_2=2.05$; w is linearly varied from 0.9 to 0.4. The method of sensitivity analysis is used to select the candidate installation locations of the capacitors to reduce the search space. The buses are ordered according to their sensitivity value ($\partial P_{line\ loss} / \partial Q_{eff}$).

Table 5.1 lists the power loss as well as the minimum voltages of the system before and after capacitor placement. The initial power loss of this system is 783.0289 kW and it is reduced to 694.6033kW after capacitor placement. This amounts to a reduction of 11.29 % in total power loss. The minimum bus voltage is 0.8376 p.u which occurs at node 10 and is improved to 0.8725 p.u (node 10) after capacitor placement. Using this method, the capacitors of rating 724.3, 1194.0, 1124.4 kVar are placed at the optimal candidate locations 9, 6 and 5 respectively has shown in Table 5.4. Voltages and Angles are listed in Table 5.2. And also voltage profile before and after capacitor placement shown in figure 5.2. The Convergence characteristics of power loss of the proposed method shown in fig.5.3. Table 5.3 lists the power flows and branch losses in each branch before and after capacitor placement. The results of the proposed algorithm are compared with Particle Swarm Optimization Algorithm [6] are presented in Table 5.5. From the results, it is observed that the power loss obtained with the proposed method is 1.6067 kW less than PSO [6] and the total kVar injected by the proposed method is less than PSO[6].

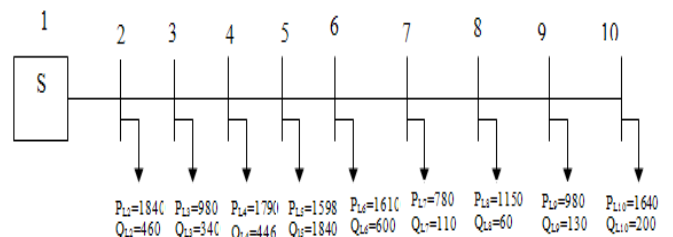

Fig 5.1. Diagram of 10 Bus Distribution System

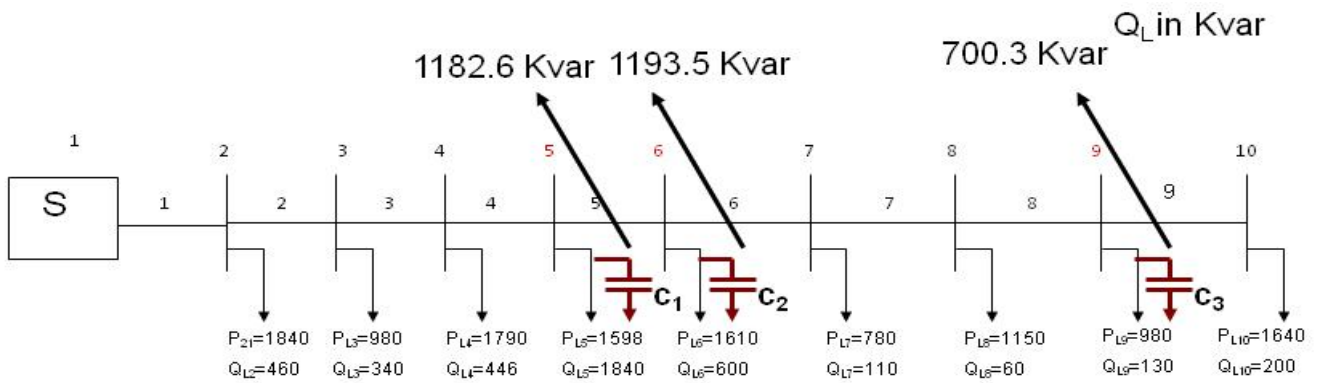

Fig 5.2: Diagram of 10 bus Distribution System with capacitors placed at 5, 6 and 9 buses whose sizing is done using DEPSO

TABLE I: Results of 10 bus system

| Items | Uncompensated | Compensated |
|----------------------|---------------|-------------|
| Total losses (Kw). | 783.0289 | 694.6033 |
| Minimum Voltage(p.u) | 0.8376 | 0.8725 |
| Total kVAr placed | - | 3042.7 |

TABLE II: voltages and angles before and after capacitor placement

| Node No. | Without Capacitor | | With Capacitor | | |
|----------|-------------------|------------|----------------|------------|--------------------|
| | Voltage(pu) | Angle(deg) | Voltage(pu) | Angle(deg) | Q-Capacitor (kVAr) |
| 1 | 1.0000 | 0 | 1.0000 | 0 | 0 |
| 2 | 0.9929 | -0.5218 | 0.9954 | -0.5591 | 0 |
| 3 | 0.9874 | -1.2677 | 0.9935 | -1.2979 | 0 |
| 4 | 0.9635 | -2.3316 | 0.9771 | -2.5891 | 0 |
| 5 | 0.9481 | -2.6529 | 0.9657 | -3.1437 | 1124.4 |
| 6 | 0.9172 | -3.7221 | 0.9423 | -4.6172 | 1194.0 |
| 7 | 0.9072 | -4.1375 | 0.9337 | -5.0903 | 0 |
| 8 | 0.8890 | -4.6192 | 0.9179 | -5.7317 | 0 |
| 9 | 0.8588 | -5.4042 | 0.8929 | -6.9221 | 724.3 |
| 10 | 0.8376 | -5.9907 | 0.8725 | -7.4636 | 0 |

TABLE III: Power flows and branch losses before and after capacitor placement

| Line No. | Connection | | Before Capacitor Placement | | | |
|----------|------------|----|----------------------------|----------------|------------------|------------------|
| | F | T | P_{ij} (p.u) | Q_{ij} (p.u) | P_{loss} (p.u) | Q_{loss} (p.u) |
| 1 | 1 | 2 | 0.131510 | 0.05222339 | 0.00046668 | 0.0015620374 |
| 2 | 2 | 3 | 0.112643 | 0.04606135 | 0.00003975 | 0.0017183862 |
| 3 | 3 | 4 | 0.102803 | 0.04094297 | 0.00176552 | 0.0028610218 |
| 4 | 4 | 5 | 0.083138 | 0.03362194 | 0.00114383 | 0.0009964360 |
| 5 | 5 | 6 | 0.066014 | 0.01422551 | 0.00190194 | 0.0016568970 |
| 6 | 6 | 7 | 0.048012 | 0.00656861 | 0.00047768 | 0.0004161100 |
| 7 | 7 | 8 | 0.039734 | 0.00505250 | 0.00075731 | 0.0004289175 |
| 8 | 8 | 9 | 0.027477 | 0.00402358 | 0.00088452 | 0.0005009829 |
| 9 | 9 | 10 | 0.016793 | 0.00222260 | 0.00039302 | 0.0002226051 |

| Line No. | Connection | | After Capacitor Placement | | | |
|----------|------------|----|---------------------------|---------------|-----------------|-----------------|
| | F | T | $P_{ij}(p.u)$ | $Q_{ij}(p.u)$ | $P_{loss}(p.u)$ | $Q_{loss}(p.u)$ |
| 1 | 1 | 2 | 0.130626 | 0.02047774 | 0.00040748 | 0.0013638992 |
| 2 | 2 | 3 | 0.111818 | 0.01451384 | 0.00003395 | 0.0014677606 |
| 3 | 3 | 4 | 0.101984 | 0.00964608 | 0.00149439 | 0.0024216585 |
| 4 | 4 | 5 | 0.082590 | 0.00276442 | 0.00094425 | 0.0008225685 |
| 5 | 5 | 6 | 0.065665 | -0.00521414 | 0.00174430 | 0.0015195720 |
| 6 | 6 | 7 | 0.047821 | -0.00079371 | 0.00044091 | 0.0003840738 |
| 7 | 7 | 8 | 0.039580 | -0.00227779 | 0.00070039 | 0.0003966821 |
| 8 | 8 | 9 | 0.027380 | -0.00327447 | 0.00081816 | 0.0004633980 |
| 9 | 9 | 10 | 0.016762 | 0.00220512 | 0.00036216 | 0.0002051282 |

TABLE IV:

Optimal candidate

locations corresponding to capacitor sizes

| No. | Bus No. | Before Capacitor Placement | | After Capacitor Placement | | |
|-----|---------|----------------------------|------------|---------------------------|------------|--------------|
| | | Voltage(pu) | Angle(deg) | Voltage(pu) | Angle(deg) | Q-Cap (kVar) |
| 1 | 9 | 0.8588 | -5.4042 | 0.8929 | -6.9221 | 724.3 |
| 2 | 6 | 0.9172 | -3.7221 | 0.9423 | -4.6172 | 1194.0 |
| 3 | 5 | 0.9481 | -2.6529 | 0.9657 | -3.1437 | 1124.4 |

TABLE V : Comparison of PSO and DEPSO for 10 bus radial distribution system. Base Active Power loss=783.0289 Kw

| Items | uncompensated | compensated | |
|----------------------|---------------|-------------|-----------------|
| | | PSO[6] | Proposed method |
| Total losses(kW) | 783.0289 | 696.21 | 694.6033 |
| Minimum Voltage(p.u) | 0.8376 | 0.8602 | 0.8725 |
| Total kVar | - | 3186 | 3042.7 |

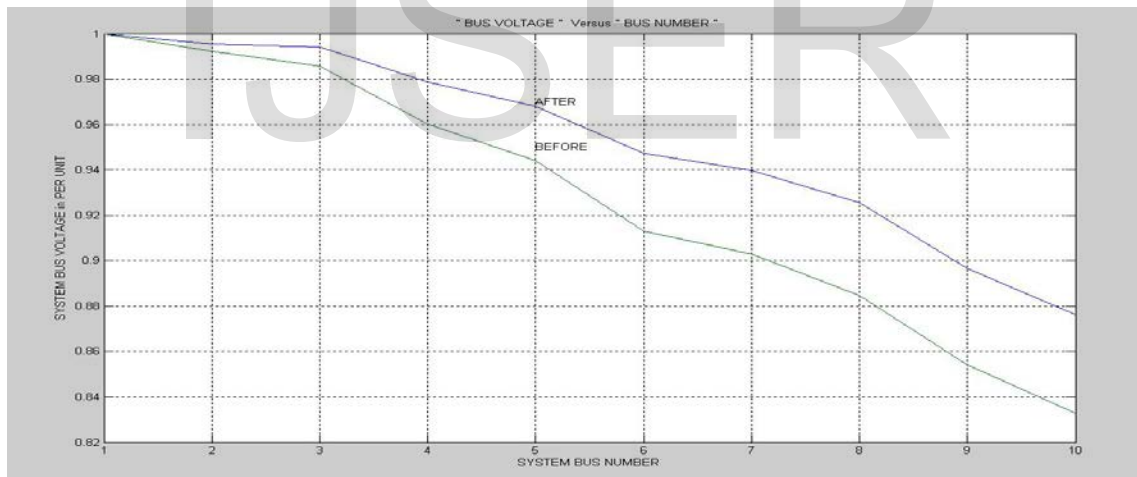

Fig 5.3: Graph showing voltages at each node before and after capacitor placement

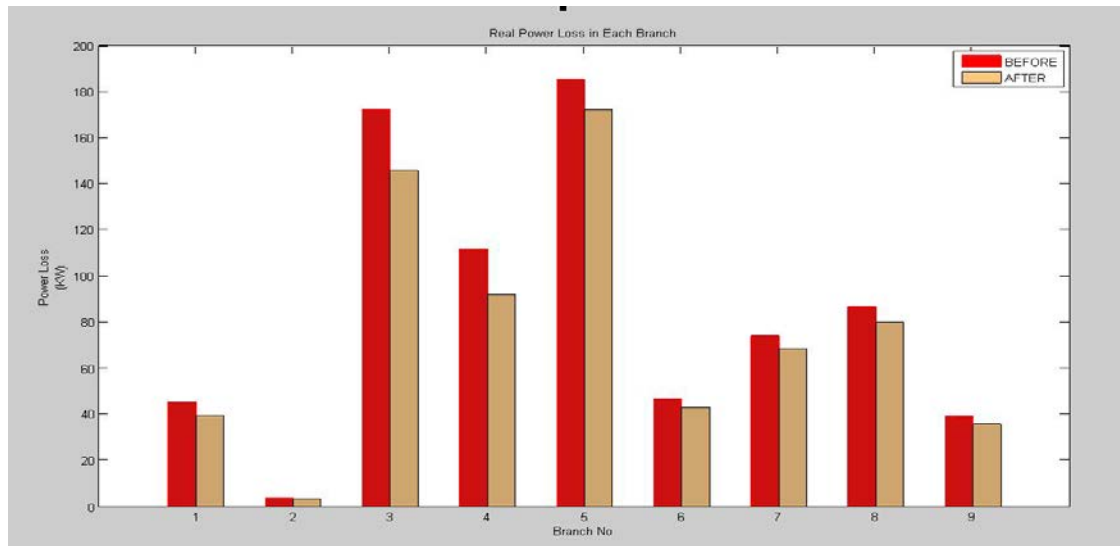

Fig 5.4: Graph showing Real Power Loss in Each Branch Before and After Capacitor Placement

VI. CONCLUSIONS

Particle Swarm Optimization with Differential Evolution (DEPSO) Algorithm is a new and efficient method for the optimization of power distribution systems, where the objective is to minimize the total real power loss and voltage profile improvement. The simulation results based on a 10 bus systems has produced the best solutions that have been found using a number of approaches available in the technical literature.

In DEPSO, in order to maintain diversity and explore the search space more efficiently, the PSO algorithm is incorporated into the DE algorithm and the particle position is updated partly in the DE way, partly in PSO normal updating way.

In this paper, the applicability of DEPSO algorithm for solving the capacitor placement problem in large scale distribution system is demonstrated. The results obtained for the example systems considered in this paper indicate that highly near optimum solutions can be achieved when compared to PSO method. . In addition, the superior features of the algorithm are simple and efficient, suitable for solving any type of objective function (irrespective of the shape) and better quality solutions.

The DEPSO method places capacitors at less number of locations with optimum sizes and offers much saving in initial investment.

REFERENCES

[1] Shouzheng Wang,lixin ma,Dashuai Sun “Hybrid differential evolution particle Swarm optimization Algorithm for reactive power Optimization”, IEEE Transactions on Power Systems, vol.9, pp. 695 - 706, 2010.

[2] Sundharajan and A. Pahwa, “Optimal selection of capacitors for radial distribution systems using genetic algorithm,” *IEEE Trans. Power Systems*, vol. 9, No.3, Aug. 1994, pp.1499-150.

[3] D. Das, “Reactive power compensation for radial distribution networks using genetic algorithms,” *Electric Power and Energy Systems*, vol. 24, 2002, pp.573-581.

[4] Ji-Pyng Chiou *et al.*, “Capacitor placement in large scale distribution system using variable scaling hybrid differential evolution,” *Electric Power and Energy Systems*, vol. 28, 2006, pp.739-745.

[5] Chung-Fu Chang *et al.*,”Robust searching hybrid differential evolution method for optimal reactive power planning in large-scale distribution systems”, *Electric Power Systems Research*, vol. 77, 2007, pp.430-437.

[6] Prakash K. and Sydulu M, “Particle swarm optimization based capacitor placement on radial distribution systems,” *IEEE Power Engineering Society general meeting 2007*. pp. 1-5.

[7] Baghzouz. Y and Ertem S, “Shunt capacitor sizing for radial distribution feeders with distorted substation voltages,” *IEEE TransPower Delivery*, Vol. 5, 1990, pp.650–57.

[8] Smarajit Ghosh and Karma Sonam Sherpa, “ An Efficient method for Load-Flow Solution of Radial Distribution Networks”, *International Journal of Electrical Power and Energy Systems Engineering*, Vol. 1, No. 2, 2008, pp. 108-115.